

SC18MLX MBP Compressor R404A/R507 220-240V 50Hz

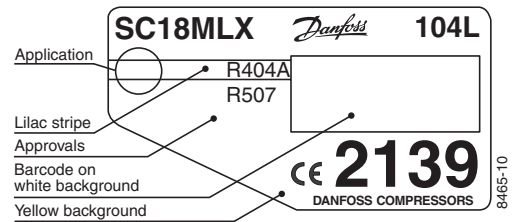

General

Code number	104L2139
Approvals	EN 60335-2-34
Compressors on pallet	80

Application

Application	MBP		
Frequency	Hz	50	60
Evaporating temperature	°C	-23.3 to 7.2	-
Voltage range	V	198 - 254	-
Max. condensing temperature continuous (short)	°C	50 (60)	-
Max. winding temperature continuous (short)	°C	125 (135)	-

Cooling requirements

Frequency	Hz	50			60		
Application		LBP	MBP	HBP	LBP	MBP	HBP
32°C		-	F ₂	-	-	-	-
38°C		-	F ₂	-	-	-	-
43°C		-	-	-	-	-	-
Remarks on application:							

- S = Static cooling normally sufficient
- O = Oil cooling
- F₁ = Fan cooling 1.5 m/s
(compressor compartment temperature equal to ambient temperature)
- F₂ = Fan cooling 3.0 m/s necessary
- SG = Suction gas cooling normally sufficient
- = not applicable in this area

Motor

Motor type	CSR		
LRA (rated after 4 sec. UL984), HST LST	A	23.4	-
Cut in Current, HST LST	A	23.6	-
Resistance, main start winding (25°C)	Ω	3.4	14.4

Design

Displacement	cm ³	17.68
Oil quantity (type)	cm ³	600 (polyolester)
Maximum refrigerant charge	g	1300
Free gas volume in compressor	cm ³	1460
Weight without electrical equipment	kg	14.0

Dimensions

Height	mm	A	219
		B	213
		B1	193
		B2	110
Suction connector	location/I.D. mm angle	C	10.2 37°
	material comment		Cu-plated steel Al caps
Process connector	location/I.D. mm angle	D	6.2 37°
	material comment		Cu-plated steel Al caps
Discharge connector	location/I.D. mm angle	E	6.2 37°
	material comment		Cu-plated steel Al caps
Oil cooler connector	location/I.D. mm angle	F	-
	material comment		-
Connector tolerance	I.D. mm		±0.09
Remarks:			

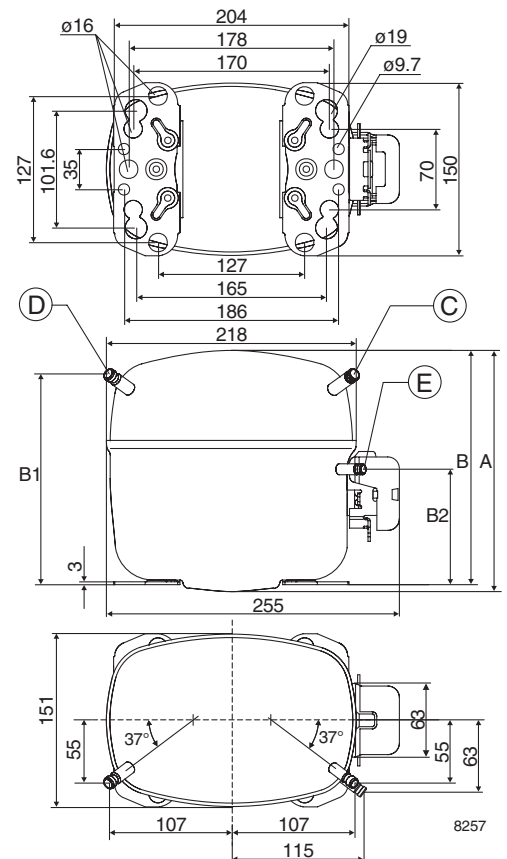

EN 12900 Household (CECOMAF) 220V, 50Hz, fan cooling F₂

Evap. temp. in °C	-45	-40	-35	-30	-25	-23.3	-20	-15	-10	-6.7	-5	0	5	7.2	10	15	20
Capacity in W						831	968	1210	1497	1712	1832	2220	2665	2880			
Power cons. in W						676	722	790	860	907	931	1004	1080	1114			
Current cons. in A						3.57	3.76	4.07	4.40	4.63	4.75	5.12	5.51	5.69			
COP in W/W						1.23	1.34	1.53	1.74	1.89	1.97	2.21	2.47	2.59			

ASHRAE MBP 220V, 50Hz, fan cooling F₂

Evap. temp. in °C	-45	-40	-35	-30	-25	-23.3	-20	-15	-10	-6.7	-5	0	5	7.2	10	15	20
Capacity in W						762	887	1111	1380	1584	1698	2072	2507	2720			
Power cons. in W						703	757	838	920	975	1003	1087	1173	1212			
Current cons. in A						3.70	3.92	4.27	4.65	4.91	5.04	5.46	5.89	6.09			
COP in W/W						1.08	1.17	1.33	1.50	1.62	1.69	1.91	2.14	2.24			

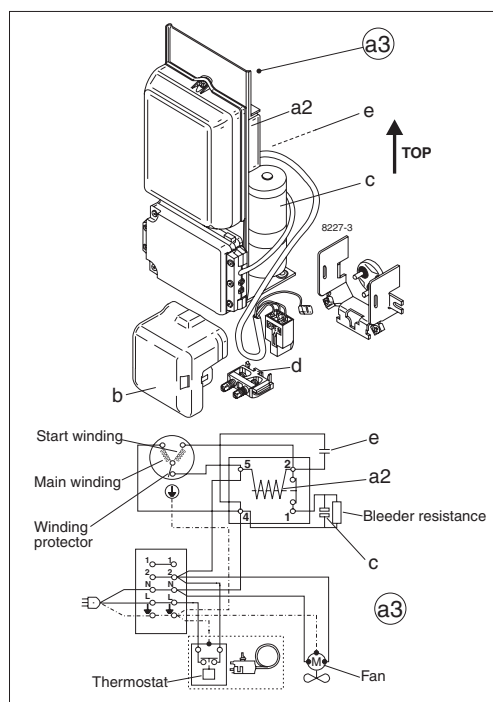

Accessories	Figure	Code number
Starting device	a3	470 mm cable length
		550 mm cable length
		1000 mm cable length
Cover	b	103N2009
Starting relay	a2	Components of starting device
Start. capacitor 80 µF	c	
Run capacitor 10 µF	e	
Cord relief	d	103N1004

Test conditions	EN 12900/CECOMAF	ASHRAE MBP
Condensing temperature	45°C	54.4°C
Ambient temperature	32°C	35°C
Suction gas temperature	32°C	35°C
Liquid temperature	no subcooling	46.1°C

Mounting accessories	Code number
Bolt joint for one compressor	Ø: 16 mm 118-1917
Bolt joint in quantities	Ø: 16 mm 118-1918
Snap-on in quantities	Ø: 16 mm 118-1919

Danfoss can accept no responsibility for possible errors in catalogues, brochures and other printed material. Danfoss reserves the right to alter its products without notice. This also applies to products already on order provided that such alterations can be made without subsequential changes being necessary in specifications already agreed. All trademarks in this material are property of the respective companies. Danfoss and the Danfoss logotype are trademarks of Danfoss A/S. All rights reserved.