

PL50F Standard Compressor R134a 115V 60Hz



General

Code number	101G9202
Approvals	UL984
Compressors on pallet	150

Application

Application	LBP/MBP			
	Hz	50	60	
Frequency	Hz	50	60	
Evaporating temperature	°F	-	-13 to 32	
Voltage range	V	-	103 - 127	
Max. condensing temperature continuous (short)	°F	-	122 (140)	
Max. winding temperature continuous (short)	°F	-	257 (275)	

Cooling requirements

Frequency	Hz	50			60		
		LBP	MBP	HBP	LBP	MBP	HBP
90°F		-	-	-	S	S	-
100°F		-	-	-	S	S	-
110°F		-	-	-	S	S	-
Remarks on application:							

Motor

Motor type	RSIR/CSIR		
LRA (rated after 4 sec. UL984), HST LST	A	6.1	9.5
Cut in Current, HST LST	A	6.1	9.5
Resistance, main start winding (77°F)	Ω	7.6	13.6

Design

Displacement	cu.in	0.12
Oil quantity (type)	fl.oz.	5.1 (polyolester)
Maximum refrigerant charge	oz.	10.5
Free gas volume in compressor	fl.oz.	28.9
Weight without electrical equipment	lbs.	9.5

Dimensions

Height	inch	A	5.28
		B	5.20
		B1	4.88
		B2	2.87
Suction connector	location, I.D. in. angle	C	0.252-0.259 41.5°
	material comment		Cu-plated steel Al cap
Process connector	location, I.D. in. angle	D	0.252-0.259 45°
	material comment		Cu-plated steel Al cap
Discharge connector	location, I.D. in. angle	E	0.202-0.205 21°
	material comment		Cu-plated steel Al cap
Oil cooler connector	location, I.D. in. angle	F	-
	material comment		-
Remarks:			

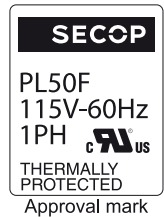
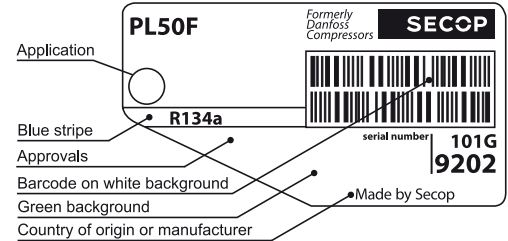

- S = Static cooling normally sufficient
- O = Oil cooling
- F₁ = Fan cooling 1.5 m/s (compressor compartment temperature equal to ambient temperature)
- F₂ = Fan cooling 3.0 m/s necessary
- SG = Suction gas cooling normally sufficient
- = not applicable in this area

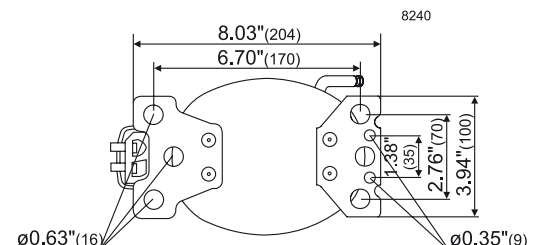
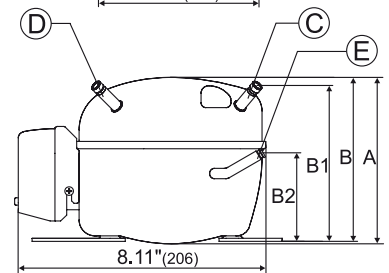
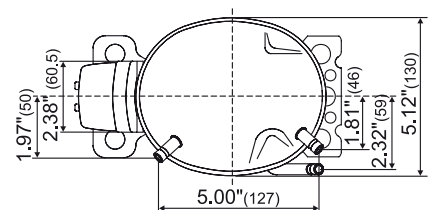

ASHRAE LBP

115V, 60Hz, static cooling, PTC consumption incl.

Evap. temp. in °F	-49	-40	-30	-20	-13	-10	0	10	14	20	30	32	41	45	50	59	68
Capacity in BTU/h					155	175	249	335	374	437	557	584					
Power cons. in W					62.3	65.0	73.2	80.9	84	88.5	96.2	97.8					
Current cons. in A					1.12	1.13	1.18	1.22	1.24	1.27	1.33	1.34					
EER in BTU/Wh					2.49	2.70	3.39	4.14	4.45	4.94	5.79	5.97					

ASHRAE MBP

115V, 60Hz, static cooling, PTC consumption incl.

Evap. temp. in °F	-49	-40	-30	-20	-13	-10	0	10	14	20	30	32	41	45	50	59	68
Capacity in BTU/h					138	156	221	299	333	388	494	518					
Power cons. in W					62.3	65.0	73.2	80.9	84	88.5	96.2	97.8					
Current cons. in A					1.12	1.13	1.18	1.22	1.24	1.27	1.33	1.34					
EER in BTU/Wh					2.21	2.40	3.02	3.69	3.97	4.38	5.14	5.29					

EN 12900 Household (CECOMAF)

115V, 60Hz, static cooling, PTC consumption incl.

Evap. temp. in °F	-49	-40	-30	-20	-13	-10	0	10	14	20	30	32	41	45	50	59	68
Capacity in W					36.8	41.5	58.9	79.3	88	103	132	138					
Power cons. in W					62.3	65.0	73.2	80.9	84	88.5	96.2	97.8					
Current cons. in A					1.12	1.13	1.18	1.22	1.24	1.27	1.33	1.34					
COP in W/W					0.59	0.64	0.80	0.98	1.05	1.17	1.37	1.41					

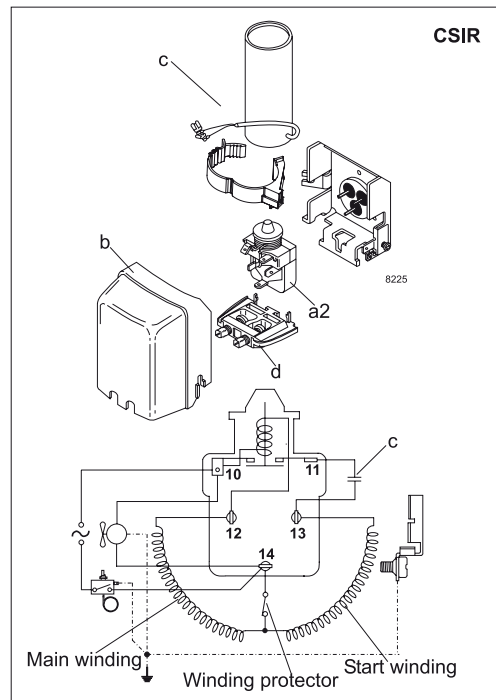
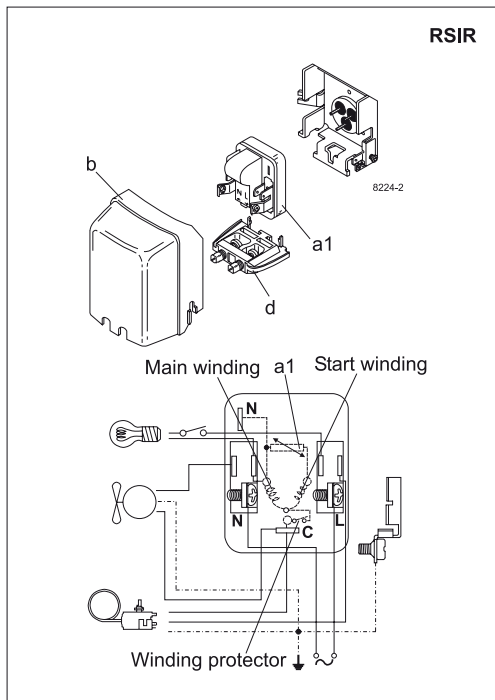

Accessories for	PL50F	Figure	Code number
PTC starting device	1/4 in. spade connect.	a1	103N0003
	3/16 in. spade connect.		103N0023
Starting relay	1/4 in. spade connect.	a2	117U6000
Cover		b	103N0492
Start. capacitor 80 µF	1/4 in. spade connect.	c	117U5015
Cord relief		d	103N1010

Test conditions	ASHRAE MBP	ASHRAE LBP*	EN 12900/CECOMAF
Condensing temp.	130°F	130°F	131°F
Ambient temp.	95°F	90°F	90°F
Suction gas temp	95°F	90°F	90°F
Liquid temperature	115°F	90°F	131°F

Mounting accessories		Code number
Bolt joint for one comp.	Ø: 5/8 in.	118-1917
Bolt joint in quantities	Ø: 5/8 in.	118-1918
Snap-on in quantities	Ø: 5/8 in.	118-1919

Danfoss can accept no responsibility for possible errors in catalogues, brochures and other printed material. Danfoss reserves the right to alter its products without notice. This also applies to products already on order provided that such alterations can be made without consequential changes being necessary in specifications already agreed. All trademarks in this material are property of the respective companies. Danfoss and the Danfoss logotype are trademarks of Danfoss A/S. All rights reserved.