



APPROVALS



ENGINEERING CODE
8630A44

APPROVED REFRIGERANT
R-290

POWER SUPPLY
220-240 V 50 Hz

STANDARD CONDITIONS
ASHRAE

APPLICATION
LBP

COOLING CAPACITY
894 W (LBP)

EFFICIENCY
1.51 W/W (LBP)

MOTOR TYPE
CSCR

STARTING TORQUE
HST

DATA

General Data

Type	Hermetic reciprocating
Technology Type	On-Off
Displacement	18.7 cm ³
Compressor Cooling	Fan/NotControlled/220
Fan Air Flow	520 m ³ /h
Expansion Device	Capillary Tube or Expansion Valve
Horse Power	1 hp
Max Condensing Pressure Operating	18.07 bar
Max Condensing Pressure Peak	20.17 bar
Power Supply	220-240 V 50 Hz
Evaporating Temperature Range	-40 °C to -10 °C

Electrical Data

Motor type	CSCR
Starting Torque	HST
Start Winding Resistance	10.43 Ω at 25° C
Run Winding Resistance	4.97 Ω at 25° C

Mechanical Data

Maximum Recommended Refrigerant Charge	150 g
Oil Charge	350 ml
Oil Type Configuration	ESTER
Oil Type Viscosity	ISO22
Pressurization	Without dry air charge
Weight	11.6 Kg
Free Internal Volume	2.6 L

Electrical Components

	Description
CSR / CSIR Box	YES
Run Capacitor	12.5
Starting Device	RVA6M3C-114
Start Capacitor	108-130 Uf / 330 V
Motor Protection	USP-Y01-83

External Characteristics

Base Plate	Universal	
Tray Holder	No	
Height	206 mm	
Connector	Internal Diameter	Shape
Suction	8.1 mm	Slanted 42°/Copper
Discharge	6.45 mm	Straight/Copper
Process	6.45 mm	Slanted 42°/Copper

PERFORMANCE

Rated Points

Condensing Temperature	Evaporating Temperature	Cooling Capacity	Power Consumption	Current	Gas Flow Rate	Efficiency
54.40°C	-23.30°C	894 W	591 W	2.8 A	9.08 kg/h	1.51 W/W

Test Condition: ASHRAELBP32, Fan/NotControlled/220, Return Gas 32.2°C, Evaporation -23.30°C, Condensing 54.40°C, Ambient 32.2°C, Liquid 32.2°C, Subcooling 22.2K. Data in accordance to EN

12900:2013 and AHRI 540:2015 polynomial equation and uncertainty guidance.

Performance Curve Data

Condensing Temperature 35°C

Evaporating Temperature °C	Cooling Capacity W	Power W	Current A	Gas Flow Rate kg/h	Efficiency W/W
-40	448	339	1.7	4.51	1.32
-35	577	392	1.92	5.82	1.47
-30	736	444	2.15	7.44	1.66
-25	925	495	2.38	9.38	1.87
-20	1145	547	2.61	11.65	2.09
-15	1397	597	2.84	14.27	2.34
-10	1681	647	3.08	17.25	2.6

Test Condition: ASHRAELBP32, Fan/NotControlled/220, Return Gas 32.2°C, Ambient 32.2°C, Liquid 32.2°C. Data in accordance to EN 12900:2013 and AHRI 540:2015 polynomial equation and uncertainty guidance.

Condensing Temperature 45°C

Evaporating Temperature °C	Cooling Capacity W	Power W	Current A	Gas Flow Rate kg/h	Efficiency W/W
-35	545	416	2.04	5.51	1.31
-30	698	474	2.28	7.06	1.47
-25	880	534	2.54	8.92	1.65
-20	1093	598	2.82	11.13	1.83
-15	1338	663	3.11	13.67	2.02
-10	1616	731	3.42	16.58	2.21

Test Condition: ASHRAELBP32, Fan/NotControlled/220, Return Gas 32.2°C, Ambient 32.2°C, Liquid 32.2°C. Data in accordance to EN 12900:2013 and AHRI 540:2015 polynomial equation and uncertainty guidance.

Condensing Temperature 55°C

Evaporating Temperature °C	Cooling Capacity W	Power W	Current A	Gas Flow Rate kg/h	Efficiency W/W
-30	653	500	2.39	6.61	1.31
-25	827	568	2.7	8.39	1.46
-20	1032	642	3.03	10.51	1.61
-15	1270	722	3.39	12.97	1.76
-10	1540	807	3.78	15.80	1.91

Test Condition: ASHRAELBP32, Fan/NotControlled/220, Return Gas 32.2°C, Ambient 32.2°C, Liquid 32.2°C. Data in accordance to EN 12900:2013 and AHRI 540:2015 polynomial equation and uncertainty guidance.

Operating Envelope

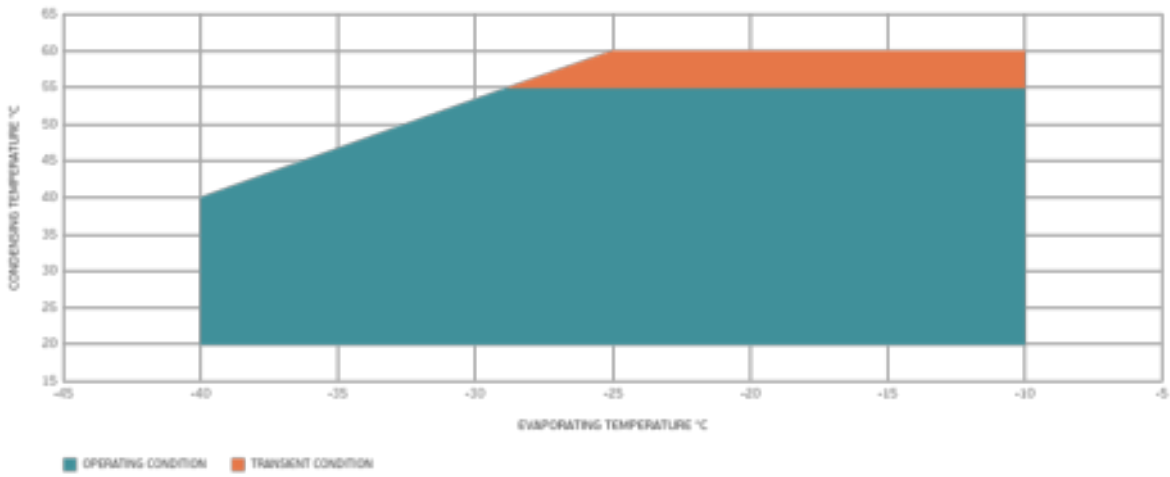

Wiring Diagram

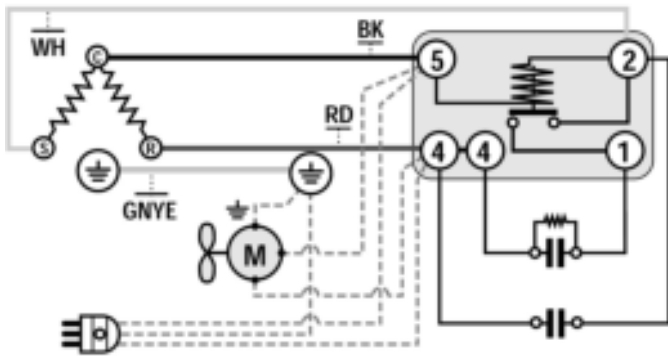

Assembly Instructions

