

COMPRESSOR

Displacement (cm ³)	20.72
Diameter (mm)	34.93
Stroke (mm)	21.62
Net Weight (Kg)	17.5
Oil type	ISO VG 46 ESTER
Oil charge (cm ³)	500

MOTOR

Approximate Power (CV)	1
Voltage/Frequency (V/Hz)	220V 50Hz
Voltage range (V)	187-264
Code	82.214
Type	CSR
Phase number	1 PH
Locked rotor current (A)	33.0
Main W. resist. at 25°C (Ω)	1.75
Start W. resist. at 25°C (Ω)	6.45

APPLICATION

Application	High/Mid. back pressure
Refrigerant	R404A
Evaporating (°C)	-25 to 10
Expansion	Capillar/Valve
Comp. cooling	Fan cooled
Max. ambient temp. (°C)	43

NOMINAL PERFORMANCE	CYCLE C	CYCLE D
Cooling capacity (kcal/h)	2085	2620
Input power (W)	1374	1415
EER (kcal/Wh)	1.51	1.85
COP (W/W)	1.76	2.15
Current (A)	6.87	7.09

TEST CONDITIONS

Evaporating temp. (°C)	5.0	7.2
Condensing temp. (°C)	55.0	55.0
Liq.t. entering expan. (°C)	55.0	46.0
Ambient t. and return (°C)	32.0	35.0
Tens/Freq (V/Hz)	220V 50Hz	220V 50Hz

ELECTRICAL COMPONENTS

Relay	3ARR3 10AS3	RVA 3G..
Pick-Up (A)	180-195	180-195
Drop-Out (A)	40-105	40-105
Protector	MRA38142	T0534/G.
Current (A)	24.0	20.0
Time check (seg)	7.5-14	7.5-14
Disc temp. (Open/Close) (°C)	120.0 / 52.0	105.0 / 52.0
Starting capacitor (μF/V)/FV)	72- 88 / 330	
Run capacitor (μF/V)	20 / 450	

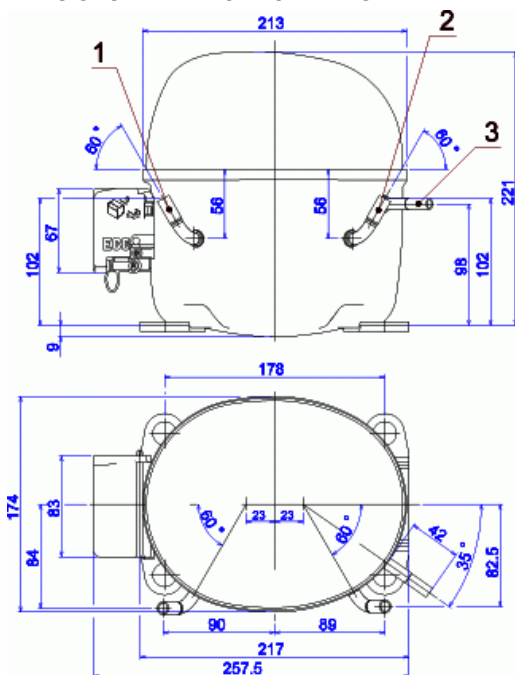
DIMENSIONS AND ELECTRICAL DIAGRAM

DESIGNATION	INTERNAL DIAM. (MM)
1	Service 9.7
2	Suction 9.7
3	Discharge 6.5

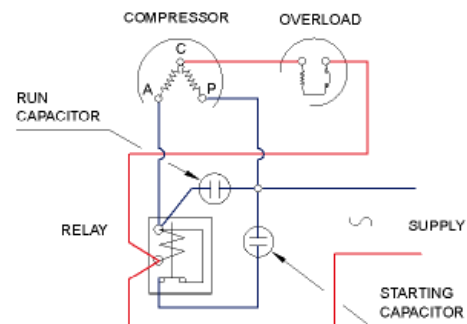
CSR

TEST CONDITIONS

Voltage/frequency	220V 50Hz
Ambient t. and return	35 °C
Liq.t. entering expan.	Subcooling 9 K

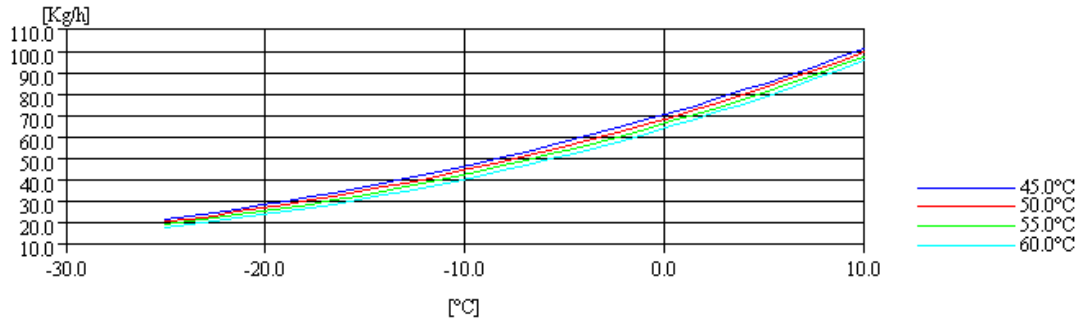
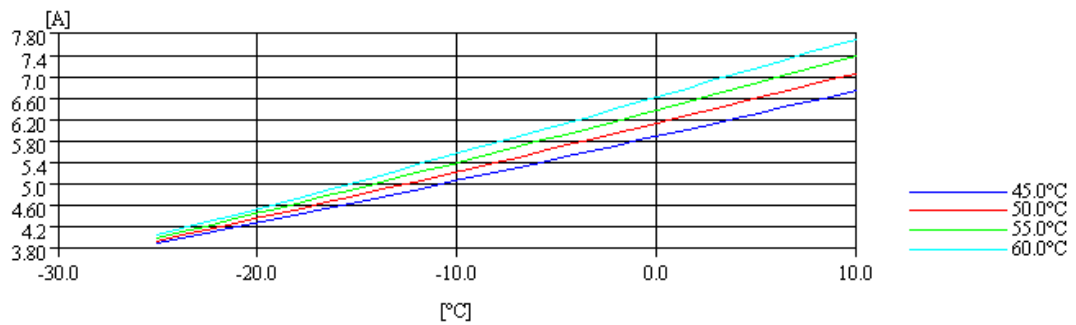
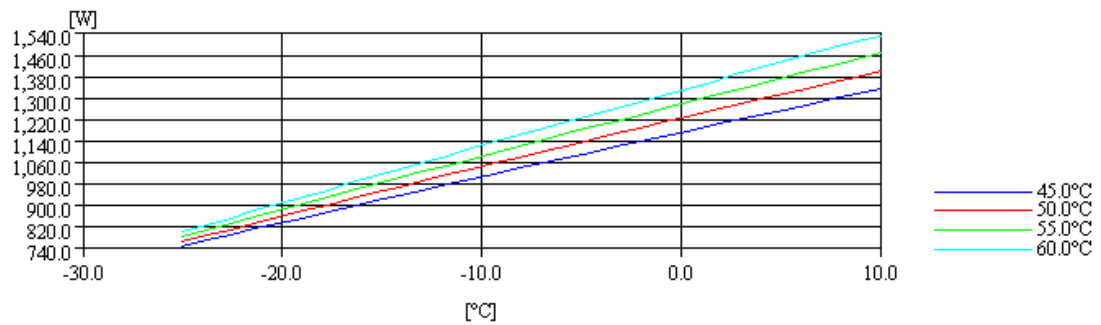
MASS FLOW

INTENSITY

CONSUMPTION

COOLING CAPACITY
